

INSTALLATION

DBE180S Dual Battery Management System



Mounting and Wiring

1. Mount the isolator high up in the engine bay away from moisture and any source of external heat (eg. Exhaust system).
2. Connect the BLACK wire to EARTH (chassis) after removing any paint from the body surface.
3. Connect the RED wire to a 12Volt ignition switched power source (12volt side of ignition switch or wiper motor circuit).
4. Connect the marked main battery cable to the positive terminal of the MAIN battery. For the isolator to function properly, the MAIN battery voltage must achieve at least 13.4V when the engine is running in its normal state. If this is not achievable (typically in older vehicles), a DBE180S model with lower 12.8V operation is available. Contact Piranha Technical Support about this model of DBE180S.
5. Connect the AUXILIARY battery cable to the positive terminal of the AUXILIARY battery.
6. Ensure AUXILIARY battery is correctly earthed.

Note: Short circuiting of any wire to the body will cause damage to both the unit and vehicle, and will also void your warranty

Testing Procedure

After mounting and wiring, to test if the unit is operating:

1. Remove the AUXILIARY cable (check writing on cable) from the AUXILIARY battery.
2. Install test light between AUXILIARY cable and EARTH.
3. Start the vehicle.
4. The test light should come on as soon as the main battery voltage exceeds 13.4 Volts. This could be within 1 sec. to 6 min. and the LED on the isolator should be GREEN. If not, check that the voltage of the MAIN battery is at least 13.4V.

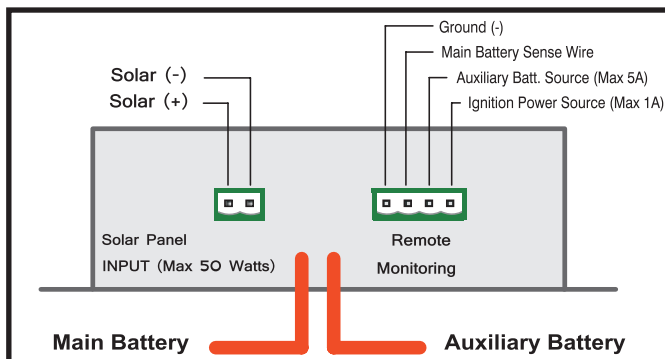

LED Indicator:

A multi-colour LED provides information on the DBE180's operation:

- LED= no colour**, when auxiliary battery is isolated from vehicle's charging system.
- LED= GREEN**, when auxiliary battery is connected to vehicle's charging system.
- LED= YELLOW**, when auxiliary battery is only receiving charge from a solar panel charger.
- LED= ORANGE**, when auxiliary battery is connected to vehicle's charging system, and also receiving charge from a solar panel charger.

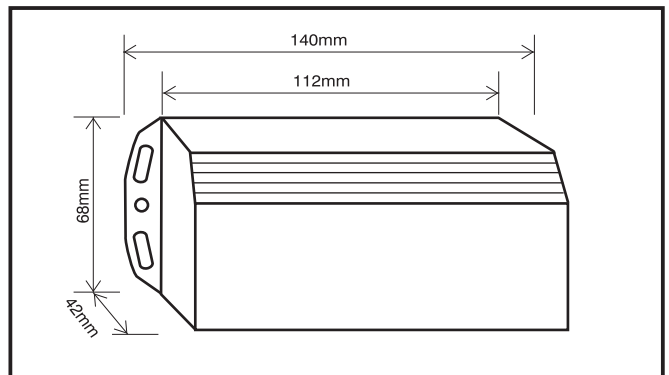

Specifications:

Dimensions

Width (of base):	140mm
Width (of box):	112mm
Height (without plugs):	68mm
Depth:	42mm

Weight

With battery cables: 1.2kg

Shipping Weight

With DBM3:	2.1kg
With DBM4:	2.5kg

Operating Specifications

Cut-In Voltage:	13.4V (12.8V model available for older vehicles)
Cut-Out Voltage:	11.5V

Suitable for Charging Systems: Up to 180A

SEE OVER FOR DETAILED WIRING DIAGRAMS



piranha
OFF ROAD PRODUCTS

Piranha Off Road Products
Factory 4, 383 Dorset Road
Boronia VIC 3155
Fh: (03) 9762 1200
Fx: (03) 9762 1400
www.piranhaoffroad.com.au

Piranha use & recommend:



AUSTRALIAN DESIGNED, MADE & OWNED

WIRING DIAGRAMS

DBE 180S+

DBE180S(+) & DBM3

WIRING DIAGRAM *DBM3 Battery Monitor*

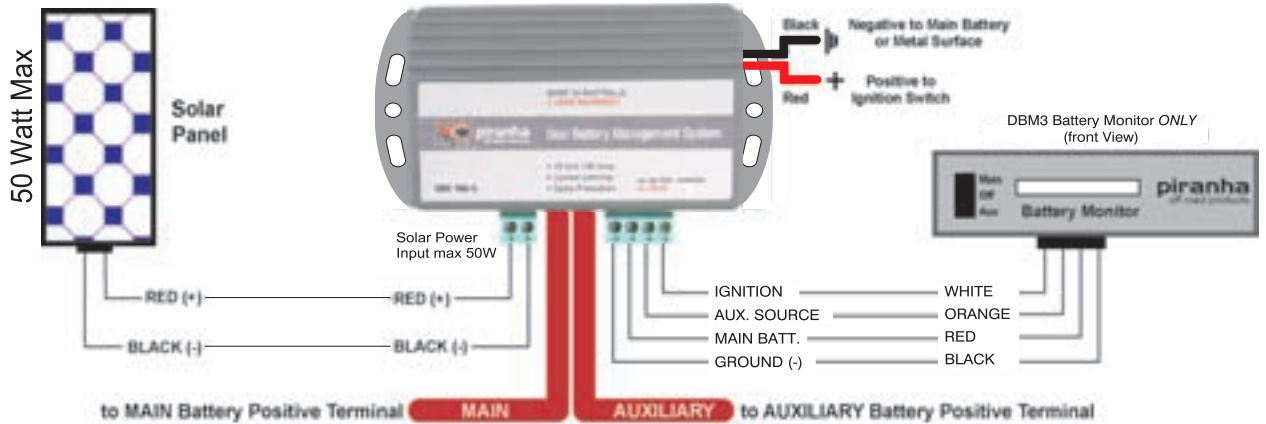

WIRING DIAGRAM (Alternative) *DBM3 Battery Monitor*

If you prefer to have the DBM3 active all the time, then this is the alternate method of wiring the product. By wiring this way you simply by-pass the 'ignition' wire and the DBM3 will be permanently connected to power from the Auxiliary Battery.

Please note that the DBM3 will use some power, even in standby mode.

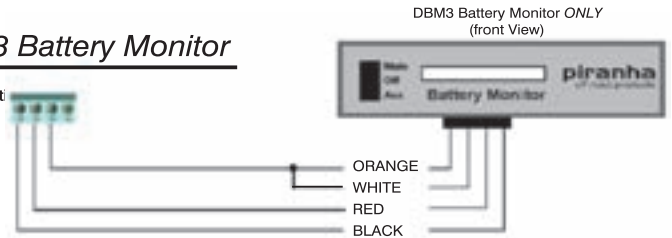

DBE180S(+) & DBM4

WIRING DIAGRAM *DBM4 Battery Protector (Monitor)*

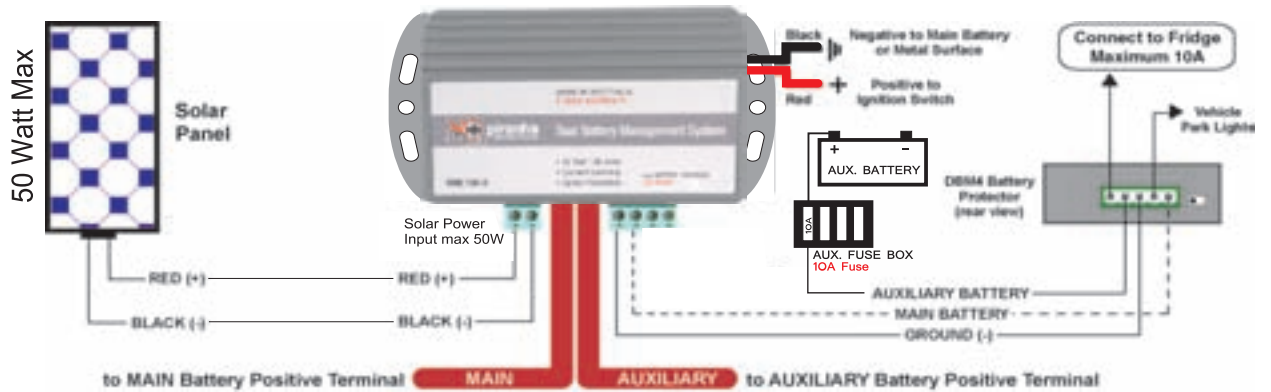

WIRING DIAGRAM (Alternative) *DBM4 Battery Monitor ONLY*

If you prefer, or do not have an auxiliary battery fuse box, the DBM4 can be mounted directly to the DBE180S+ and used as a monitor only.

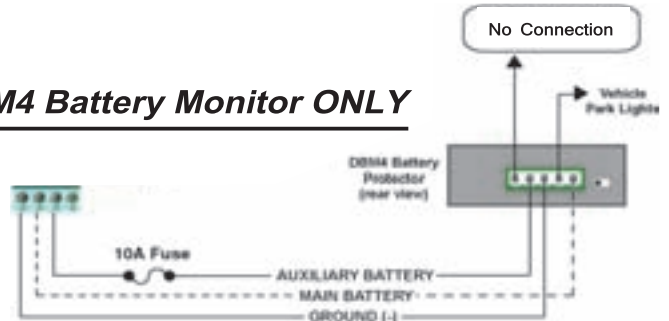

- WARNING:**
- DO NOT exceed the 5A Limit when connecting a device to the 'Auxiliary Battery' position of the DBE180S 4-terminal connector. Exceeding the 5A Limit will cause damage to the DBE180S.
 - Winching may overload your vehicle's alternator and charging system. DO NOT winch from the Auxiliary Battery! Consult the owner's manual of the winch. A dual battery kit does not necessarily protect you from overloading the vehicle's charging system. Consult your Piranha dealer for specific information on this issue.
 - If using DBM4 Battery Protector with the low voltage cut out - it is necessary to follow the DBM4 protector wiring diagram precisely.